

Sir Donald Bailey, 1901-1985





Bailey Bridge over Meurthe River, France

Bailey Bridge

- **Easy to assemble modular bridge for spans up to 60m long, strong enough to carry tanks.**
- **Simple shaped, interchangeable steel parts.**
- **Small parts of the bridge could be easily carried by soldiers.**
- **Requires no special tools or heavy equipment to fabricate.**
- **President Eisenhower acclaimed it, after the War, as one of the three pieces of equipment that most contributed to victory in Europe.**



Bailey Configurations

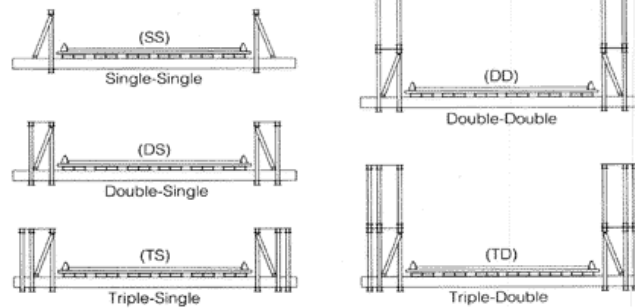

Standardized Components

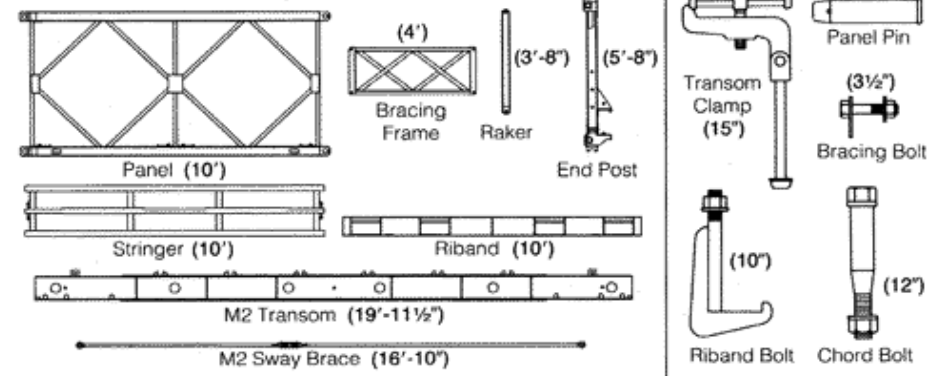



Terence Cuneo's painting, *Bridging the Rapido at Monte Cassino* depicts the British Royal Engineers' launch of an 80ft Class 30 Bailey bridge, built under constant fire on the night of the 12-13 May 1944.



**Launching a Bailey bridge; painting
by Ludwig Mactarian**